



















TABLA DE SELECCIÓN

	2 módulos	2+2 módulos	2+2+2 módulos	2+2+2+2 módulos
Cajas para albañilería	 080141 (40 mm) 080151 (50 mm)	 080141 (40 mm) x 2 080151 (50 mm) x 2	 080141 (40 mm) x 3 080151 (50 mm) x 3	 080141 (40 mm) x 4 080151 (50 mm) x 4
Cajas para tabique hueco	 080051 (50 mm)	 080052 (50 mm)	 080053 (50 mm)	 080054 (50 mm)
Soportes*	 K4702	 K4702	 K4702	 K4702
Nº de módulos	 2 módulos	 2+2 módulos	 2+2+2 módulos	 2+2+2+2 módulos
Placas**	 KA4802...	 KA4802M2...	 KA4802M3...	 KA4802M4...
Nº de teclas de 1 módulo para completar el mecanismo	 2 teclas	 2+2 teclas	 2+2+2 teclas	 2+2+2+2 teclas

Nota: (*) se suministra sin tornillos. Sujeción utilizando los tornillos suministrados con las cajas de empotrar.
 (**) instalación tanto horizontal como vertical

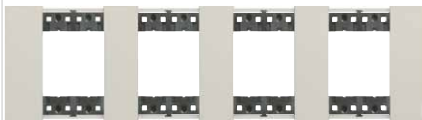
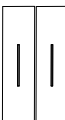
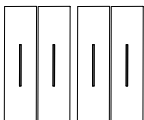
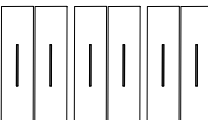
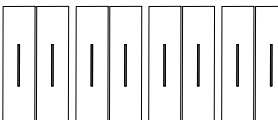

- Nota: protector suministrado con los soportes, disponible en todas las modularidades.

Se utiliza:

- *in situ*, antes de la instalación de las placas embellecedoras y las teclas/frontales
- después de retirar las placas y las teclas/frontales al pintar las paredes

Living Now
Ejemplos de instalación

EJEMPLO DE INSTALACIÓN DEL MECANISMO COMPLETO CON TECLAS DE 1 MÓDULO



EJEMPLO DE COMPOSICIÓN DE UN MECANISMO COMPLETO

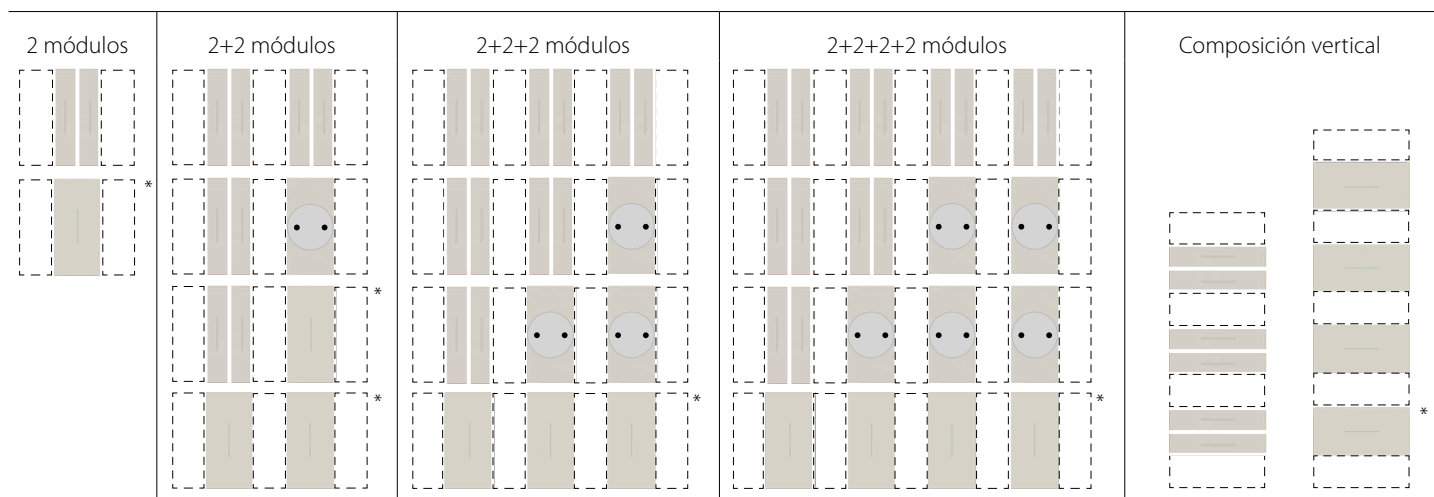

Nota: para la instalación de mecanismos de 1 módulo con teclas de 2 módulos es necesario utilizar dos "medios módulos ciegos", ref. K4949 (véase el diagrama de ejemplo siguiente)











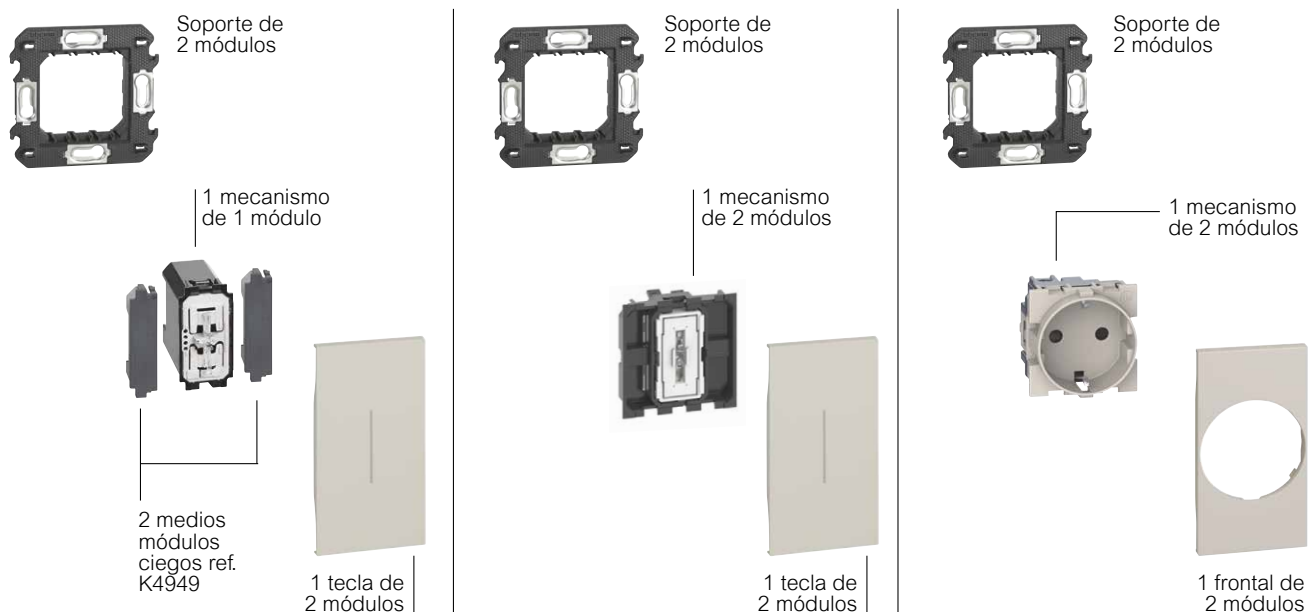

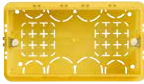



TABLA DE SELECCIÓN

Cajas para albañilería	<p>3 módulos</p>  <p>503E (108 x 74 x 53,5 mm)</p>	<p>4 módulos</p>  <p>504E (133 x 74 x 53,5 mm)</p>	<p>6 módulos</p>  <p>506L (183,5 x 90 x 53,5 mm)</p>
Cajas para tabique hueco	 <p>PB503N (110 x 71 x 52 mm)</p>	 <p>PB504N (132,5 x 71 x 52 mm)</p>	 <p>PB506N (183 x 71 x 52 mm)</p>
Soportes	 <p>K4703 con tornillos</p>	 <p>K4704 con tornillos</p>	 <p>K4706 con tornillos</p>
Nº de módulos	 <p>3 módulos</p>	 <p>4 módulos</p>	 <p>6 módulos</p>
Placas	 <p>KA4803...</p>	 <p>KA4804...</p>	 <p>KA4806...</p>
Nº de teclas de 1 módulo para completar el mecanismo	 <p>3 teclas</p>	 <p>4 teclas</p>	 <p>6 teclas</p>

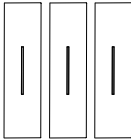
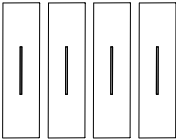
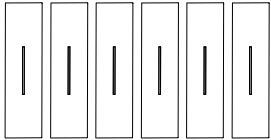

- Nota: protector suministrado con los soportes, disponible en todas las modularidades.

Se utiliza:

- *in situ*, antes de la instalación de las placas embellecedoras y las teclas/frontales
- después de retirar las placas y las teclas/frontales al pintar las paredes

Living Now
Ejemplos de instalación

EJEMPLO DE INSTALACIÓN DEL MECANISMO COMPLETO CON TECLAS DE 1 MÓDULO



EJEMPLO DE COMPOSICIÓN DE UN MECANISMO COMPLETO

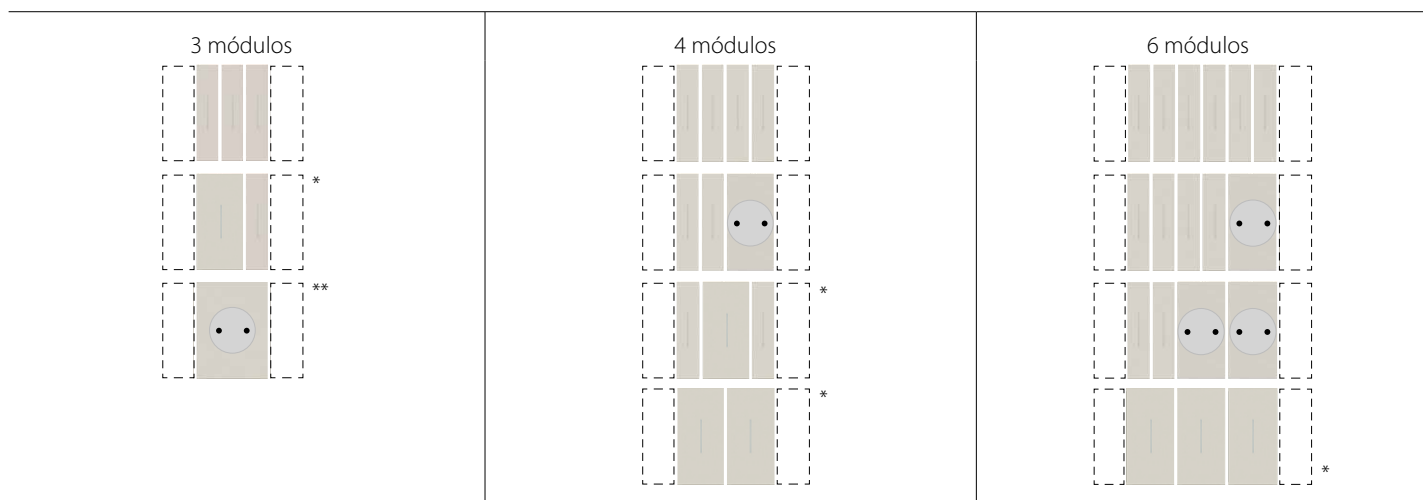















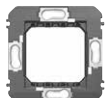







Nota: para la instalación de mecanismos de 1 o 2 módulos centrados en soportes de 3 módulos es necesario utilizar “medios módulos ciegos”, ref. K4949 (véanse los diagramas de ejemplo siguientes)



COMPOSICIÓN DE COMANDOS DIGITALES

Para cada tipo de caja, se indican los marcos electrificados utilizados y el número de dispositivos y accesorios que se pueden instalar.

	2 módulos	3 módulos	4 módulos		
Cajas de empotrar	 080141 (40 mm) 080151 (50 mm)	 503E (108 x 74 x 53,5 mm)	 504E (133 x 74 x 53,5 mm)		
Cajas para tabique hueco	 080051 (50 mm)	 PB503N (110 x 71 x 52 mm)	 PB504N (132,5 x 71 x 52 mm)		
Soportes	 K8102	 K4703 con tornillos	 K4704 con tornillos		
Cajas de empotrar - módulo de conexión K8001; - actuadores K8002L y K8002S; - alimentación adicional K8003 (2 módulos).		 3 módulos	 4 módulos		
Módulo ciego K4950		 máx. 2 módulos ciegos	 máx. 3 módulos ciegos		
Marco electrificado	 3 módulos ..8102P1	 3 módulos ..8103	 3+1 módulos ..8103P1	 4 módulos ..8104	 4+1 módulos ..8104P1
Control por voz referencia..8013 (3 módulos) Comandos iluminación Referencia ..8010 y Comando completo ..8011 Tapa para módulo ciego ref 4950					

ADVERTENCIA SOBRE LA SELECCIÓN DE LOS DISPOSITIVOS:

- Nota (*) El módulo de conexión es necesario; se puede colocar en cualquier lugar dentro de la caja.
- Si es necesario instalar la fuente de alimentación adicional, ref. K8003, para la función de control por voz, ref.8013 (consulte la guía MyHOME_Up, que ofrece más detalles) no se debe instalar el módulo de conexión con ref. K8001. La alimentación adicional (espacio necesario 2 módulos) solo puede instalarse en el marco electrificado o junto con 1 o 2 actuadores, en función del tamaño de la caja.

EJEMPLO DE INSTALACIÓN DE LOS COMANDOS DIGITALES

Instalación con actuador empotrado

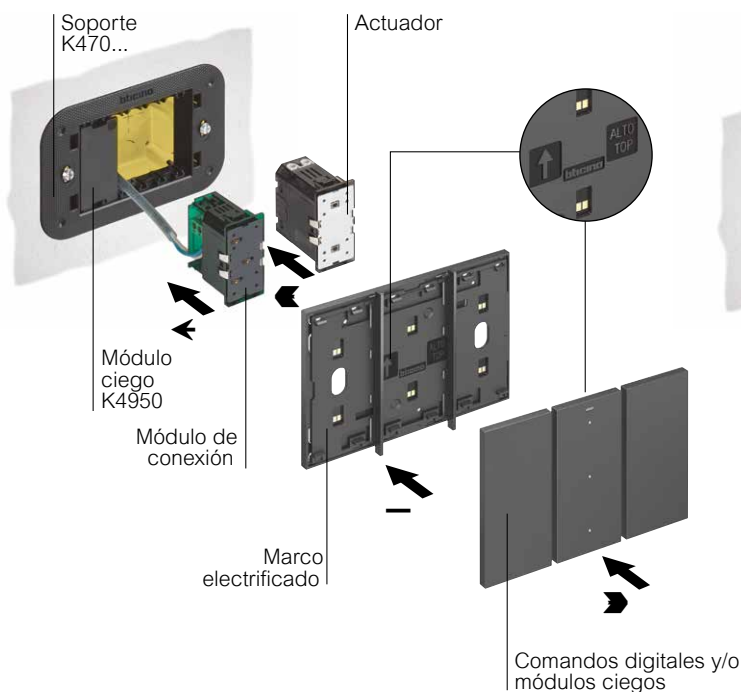

Se utiliza junto con el módulo de conexión u otro actuador para detectar la tensión de alimentación.

Instalación con actuador en el cuadro eléctrico DIN

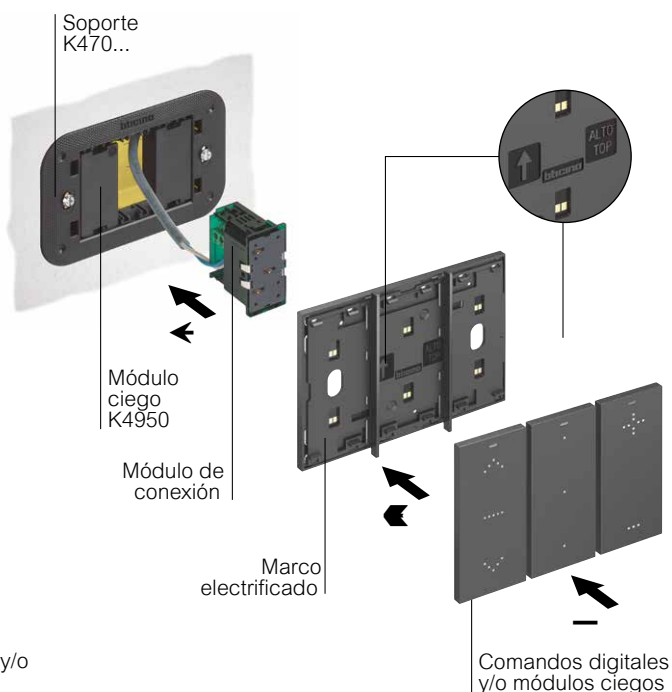

En el lateral del módulo de conexión, instale 2 módulos ciegos, ref. K4950, en cualquier posición.

Instalación del control por voz

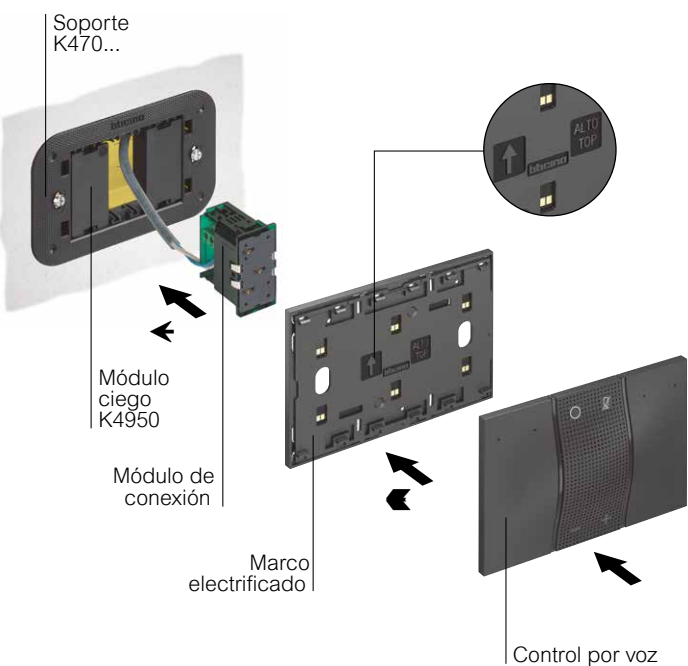

Retire las barras estéticas del marco electrificado. Si se instala la fuente de alimentación ref. K8003, no debe utilizarse el módulo de conexión ref. K8001.